



ELECTRONICS, INC.
 44 FARRAND STREET
 BLOOMFIELD, NJ 07003
 (973) 748-5089
<http://www.nteinc.com>

NTE30030 thru NTE30036, NTE30044 Super Bright LED Indicators, 3mm

Features:

- All Plastic Mold Type w/Water Clear Lens:
 - NTE30030 (Yellow Green, AlGaP/GaAs)
 - NTE30031 (Pure Green, GaInN/GaN)
 - NTE30032 (Yellow, AlInGaP/GaAs)
 - NTE30033 (Orange, AlInGaP/GaAs)
 - NTE30034 (Deep Red, GaAlAs/GaAlAs)
 - NTE30035 (Amber, AlGaP/GaAs)
 - NTE30036 (Blue, GaInN/GaN)
 - NTE30044 (White, GaInN/GaN)

Absolute Maximum Ratings: ($T_A = +25^\circ\text{C}$ unless otherwise specified)

Reverse Voltage, V_R	5V
Continuous Forward Current, I_F	
NTE30030, NTE30032, NTE30033, NTE30034, NTE30035	25mA
NTE30031, NTE30036, NTE30044	30mA
Peak Forward Current (1.10 Duty Cycle, 0.1ms Pulse Width), I_{FM}	
NTE30030, NTE30032, NTE30033, NTE30034, NTE30035	50mA
NTE30031, NTE30036, NTE30044	100mA
Power Dissipation, P_D	
NTE30030, NTE30032, NTE30033, NTE30035	100mW
NTE30034	110mW
NTE30031, NTE30036, NTE30044	120mW
Operating Temperature Range, T_{opr}	-25°C to $+85^\circ\text{C}$
NTE30036 Only	-40°C to $+85^\circ\text{C}$
Storage Temperature Range, T_{stg}	-40°C to $+100^\circ\text{C}$
Lead Temperature (During Soldering, .063 (1.6mm) from body, 5sec max), T_L	$+240^\circ\text{C}$

Electro-Optical Characteristics: ($T_A = +25^\circ\text{C}$ unless otherwise specified)

Parameter	Symbol	Test Conditions	Min	Typ	Max	Unit
Forward Voltage	V_F	$I_F = 20\text{mA}$	-	2.2	2.4	V
NTE30030						
NTE30031						
NTE30032, NTE30035						
NTE30033						
NTE30034						
NTE30036						
NTE30044						

Electro-Optical Characteristics (Cont'd): ($T_A = +25^\circ\text{C}$ unless otherwise specified)

Parameter	Symbol	Test Conditions	Min	Typ	Max	Unit
Reverse Current All Devices	I_R	$V_R = 5V$	-	-	10	μA
NTE30031, NTE30036		$V_R = 4V$	-	-	60	μA
NTE30044 Only		$V_R = 5V$	-	-	50	μA
Luminous Intensity NTE30030	I_V	$I_F = 20\text{mA}$, Note 1	-	1600	-	mcd
NTE30031			-	5000	-	mcd
NTE30032, NTE30033, NTE30035			-	2500	-	mcd
NTE30034			-	2000	-	mcd
NTE30036			2000	3000	-	mcd
NTE30044			6000	7000	-	mcd
Peak Emission Wave Length NTE30030	λ_P	$I_F = 20\text{mA}$	-	575	-	nm
NTE30031			-	523	-	nm
NTE30032			-	592	-	nm
NTE30033			-	620	-	nm
NTE30034			-	660	-	nm
NTE30035			-	607	-	nm
NTE30036			-	468	-	nm
NTE30044		CIE Coordinates, Typ	X: 0.28; Y: 0.30			
Dominate Wave Length (NTE30036 Only)	$\lambda_d(\text{HUE})$	$I_F = 20\text{mA}$, Note 2	465	470	475	nm
Spectral Line Half Width NTE30030, NTE30033, NTE30034, NTE30035	$\Delta\lambda$	$I_F = 20\text{mA}$	-	20	-	nm
NTE30031			-	45	-	nm
NTE30032			-	25	-	nm
NTE30036			-	20	-	nm
NTE30044			-	22	-	nm
Viewing Angle NTE30030, NTE30031	$2\theta^{1/2}$	$I_F = 20\text{mA}$	-	14	-	deg.
NTE30032, NTE30033, NTE30035			-	10	-	deg.
NTE30034			-	19	-	deg.
NTE30036			-	10	-	deg.
NTE30044			-	30	-	deg.
Optic Rise Time (NTE30036 Only)	τ	$I_F = 20\text{mA}$	-	30	-	ns

Note 1. Luminous intensity is measured with an Exeltron 2001.

Note 2. The dominate wavelength, λ_d , is derived from the CIE Chromaticity Diagram and represents the color of the device.

NTE30030 thru NTE30036

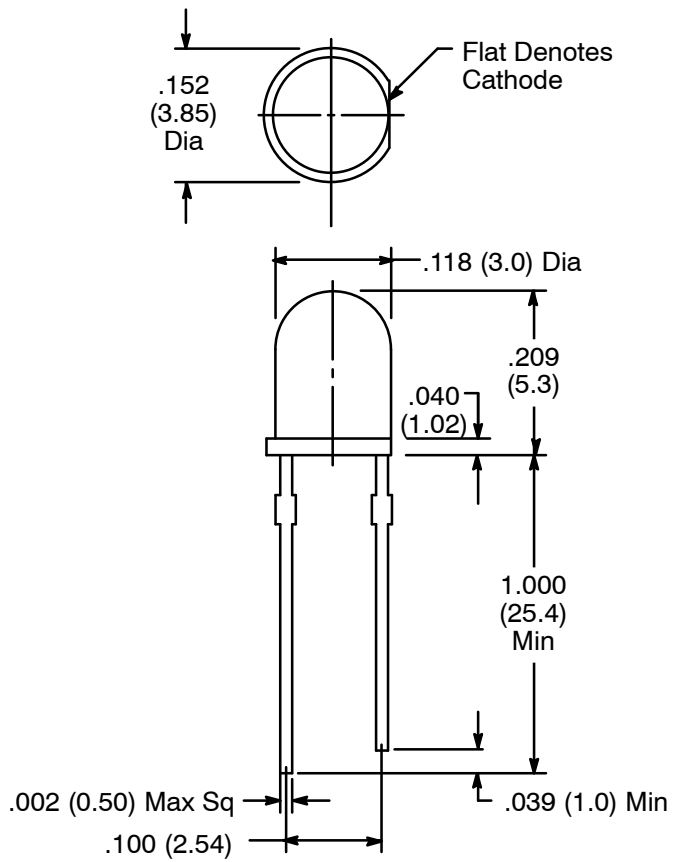

NTE30044, NTE30036

